

FREE MENU CREATOR

By : André Blavier (Rank Xerox France)

This document last edited on September 29, 1988

The Free Menu Creator application is designed to create interactively Free Menu description lists.

It is a full graphical tool with which you can move, shape, box, group the Free Menu Items and attach properties to them. At any time you can make the application compute the description list and then test the Free Menu that you have just created.

OPENING A FREE MENU CREATOR (FMC) WINDOW

Once you have loaded the application the 'FMCreator' option is added to the background menu. By selecting it you will create a FMC window of the form:

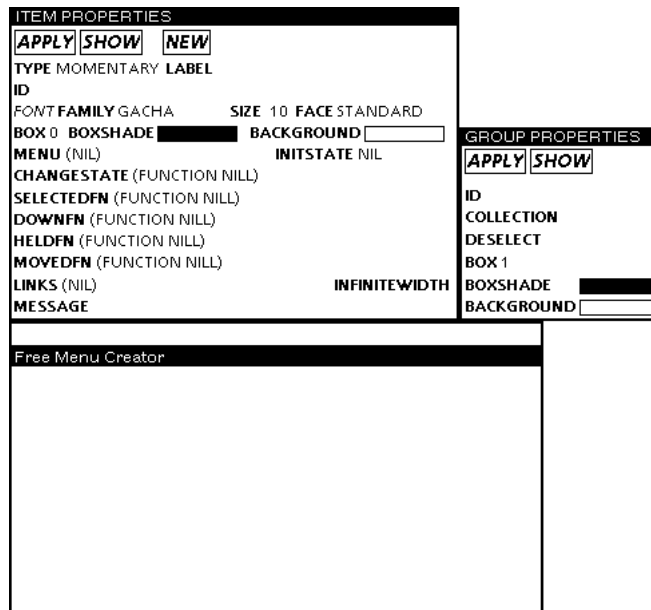

The bottom window is the **main window** : you will add, move ... items to it.

Two menu windows (Free Menus in fact) are attached on top of the main window : the **Item Properties menu** (IP menu) and the **Group Properties menu** (GP menu). They are provided for setting and changing item or group properties.

Between the menus and the main window is the **Prompt window**. Its purpose is mainly to display various information such as messages, prompts ...

THE RIGHT BUTTON MENU

Pressing the right button inside the main window will pop up the following menu:

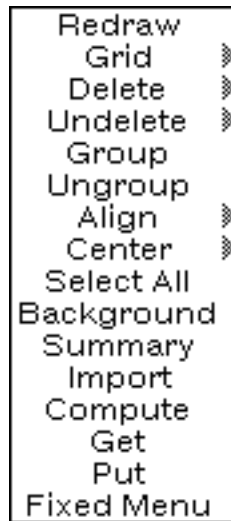

You can fix this menu on the right edge of the main window by selecting the 'Fixed Menu' option.

A SAMPLE SESSION

Suppose you want to create the following Free Menu (this example is taken from the FREE MENU Lyric Release Notes):

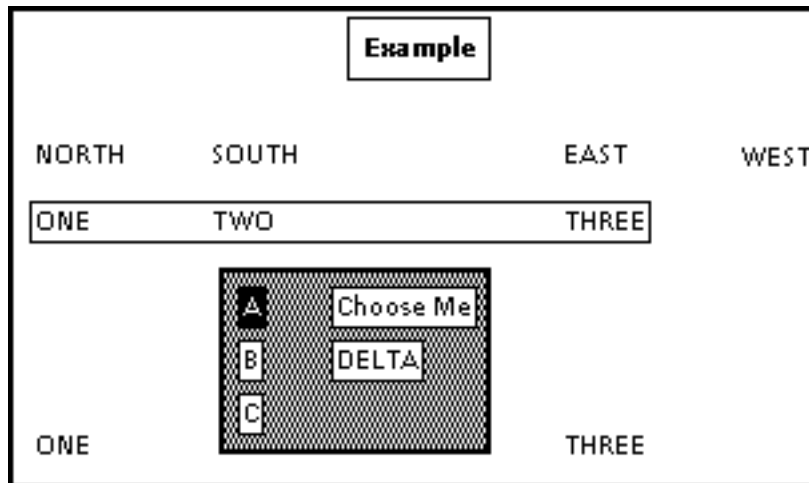

First create the 'Example' item:

- select **TYPE** in the IP menu : the following pop-up menu appears:

TYPE
MOMENTARY
TOGGLE
3STATE
STATE
NWAY
EDIT
NUMBER
EDITSTART
DISPLAY

- choose the type of item you want to create, e.g. DISPLAY
- select **LABEL** in the IP menu and type 'Example'
- choose the font by clicking in the **FAMILY**, **SIZE** and **FACE** items, which will cause the following menus to pop up:

FAMILY	SIZE	FACE
CLASSIC	6	REGULAR
MODERN	7	ITALIC
TERMINAL	8	BOLD
TITAN	9	BOLDITALIC
GACHA	10	
HELVETICA	11	
TIMESROMAN	12	
	14	
	18	
	24	
	30	
	36	

- now, the properties you wanted for that new item are set. So click in the **NEW** field and then move the mouse to the place where you want to put the item.

When you release the mouse button the item is fixed in the window. it is surrounded by a gray rectangle which means that it is **selected**:

Example

If you move the mouse inside the selection rectangle the cursor will change to:



By pressing the left button while the cursor is inside a selection, you can move that selection.

Repeat the same operation for the 'NORTH', 'SOUTH', 'EAST', 'WEST', 'ONE', 'TWO' and 'THREE' items.

To place the items exactly where you want you can use (and combine) the following facilities:

- use the **GRID** (from the right menu):

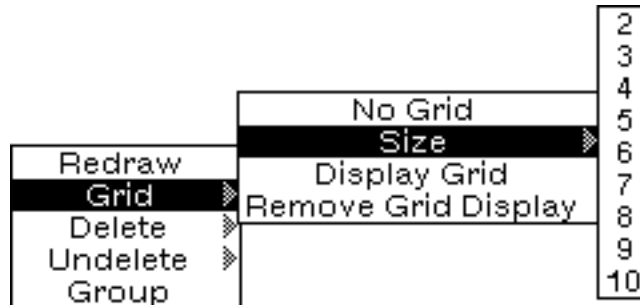

- align and center a **multiple selection** :

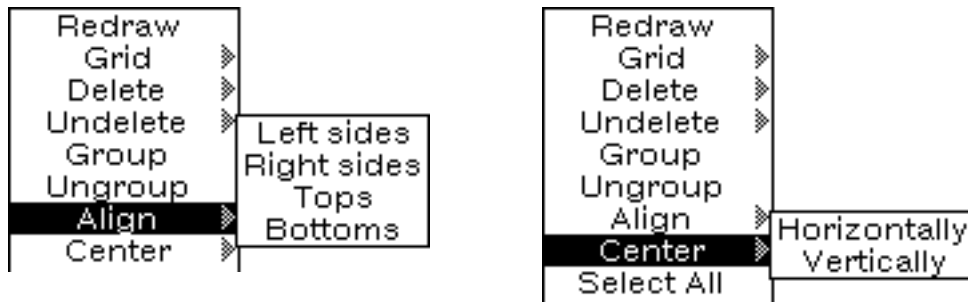

Select multiple items by pressing the left button and the **META** key, while the cursor is above them. You can also extend a multiple selection by pressing Left-Meta outside any item and shaping a ghost region :

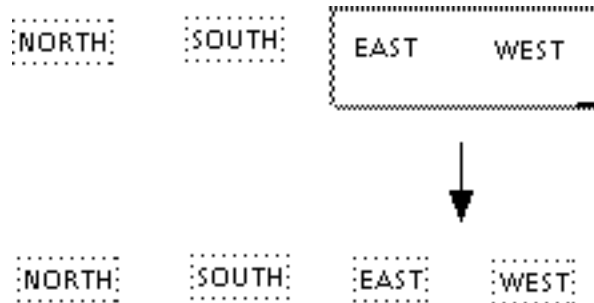

Each item of a multiple selection is surrounded by a dotted rectangle. You can move a multiple selection in the same way you move a unique selection.

The **Align** and **Center** functions all refer to the first selected item. For example, if you choose 'Align Tops' then all the items except for the first one will be moved so that their top is at the same Y coordinate as that of the first item :

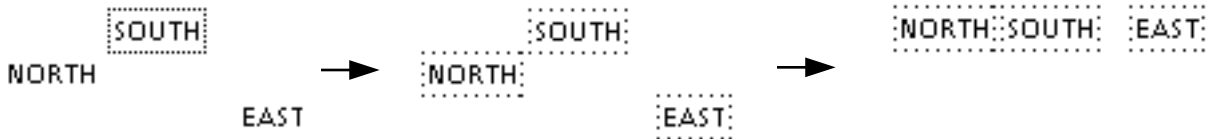

Now, let's box the 'Example' item :

- select the item

- select **SHOW** in the IP menu : this updates the menu according to the item
- set the BOX and BOXSHADE properties :

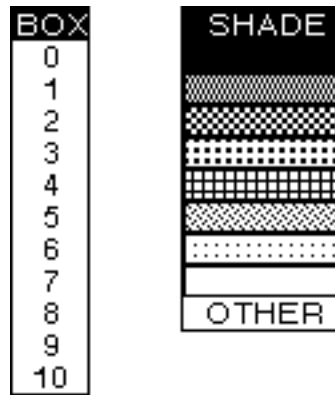

- select **APPLY** : the item is redisplayed surrounded by a box
- press the middle button inside the item : you can now shape the box (the shaping is controlled so that the space between the item and its box is the same horizontally and vertically) :

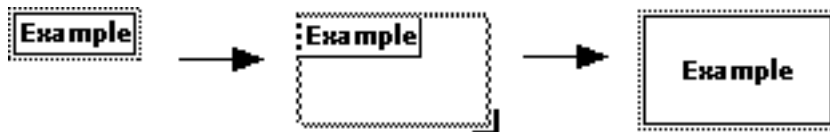

Whenever you need to change some items's property (ies) , select the item and then select **SHOW** in the IP menu : this updates the menu according to the item. Then, you can change any property, and update the item according to the IP menu by selecting **APPLY**.

You can also change properties of multiple items : make a multiple selection, set the property (ies) you want to change, then select **APPLY** : the following menu pops up :



Only the selected property will be applied to the items.

When setting a box property on multiple items, a box is created around each item, not around the whole selection. To wrap a set of items by a box you must first **GROUP** the items. That's what we want to do for the 'ONE', 'TWO', 'THREE' items :

- select the items
- choose **GROUP** from the right menu

Groups are automatically boxed at creation. You can modify groups in the same way as you modify simple items, using the GP menu. Groups can be moved and shaped like simple items.

Now, create the 'A', 'B', 'C' items, setting their TYPE to NWAY. Group the items, select **SHOW** in the GP menu, set COLLECTION to 'COL1', set DESELECT to T - then select **APPLY** : you have created the collection.

Create the 'DELTA' item and then the 'Choose Me' STATE item. For this last item specify a MENU property, selecting **MENU** in the IP menu. This opens the following SEdit window :

```
SEdit Package: INTERLISP
(("ITEMS") "[FONT]" "[TITLE]")
```

The first element of the list should be an item list, as suitable for standard menus. The second and third elements are optional : FONT should be a list of the form (FAMILY SIZE FACE), TITLE should be a listatom or a string.

Edit the list ((BRAVO DELTA) (MODERN 12 ITALIC)) and close the SEdit window. Now, select **INITSTATE** : this will pop up the following menu :



As you can see the items you just edited are part of this menu. Select DELTA.

One more property is required : the **LINKS** property. Select LINKS : the following menu appears :

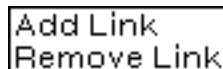

Choose 'Add Link' and click on the DELTA item : the link is created.

At any time you can create the actual Free Menu out of your FMC window by selecting the **COMPUTE** option from the right menu. This creates the description list, which is stored in the **FM-DESCRIPTION** global variable. A call to the FREEMENU function is done automatically with FM-DESCRIPTION as an argument, and the Free Menu window is opened.

REFERENCE GUIDE

General window behavior

The main window, the prompt window and the properties windows behave as a whole. Moving, shaping, shrinking and closing can be directed from anyone of them. Shaping affects only the main

window. Closing is protected by a confirmation request when unsaved modifications have occurred. The main window is not scrollable.

The right menu, when fixed, can be closed solely.

Hardcopying the main window does not use the standard hardcopy functions. Instead, the contents is 'pretty-hardcopied', but the current version can't print large windows on multiple pages.

The right menu

Redraw : use Redraw to redisplay the contents of the window. This can be useful when items overlap.

Grid : selecting the Grid option displays the grid state in the prompt window.

No Grid : removes the grid.

Size suboptions : specifies a grid size (in pixels). Grid alignment refers to the lower left corner of items.

Display Grid : displays the grid in the window.

Remove Grid Display : removes the grid display, but the grid remains active.

Delete : deletes the selected item(s). Items deleted are saved in a list so they can be undeleted. The number of deleted items is displayed in the prompt window.

Forget save list : deleted items are destroyed and can't be undeleted.

Undelete : undeletes last deleted item.

Last : same effect

All : undeletes all deleted items

List : pops up a menu of all the deleted items. The selected item gets undeleted.

Group : groups a multiple selection. A group can include groups. The components of a group are not individually accessible.

Ungroup : unpacks a group. The ungrouping operation works only at the first level, i.e. included groups are not unpacked.

Align : the Align suboptions all work on a multiple selection (items and/or groups). The alignment operation refers to the first selected item.

Left sides : align left sides of selected items

Right sides : align right sides of selected items

Tops : align tops of selected items

Bottoms : align bottoms of selected items

Center : the Center suboptions all work on a multiple selection (items and/or groups). The centering operation refers to the first selected item.

Horizontally : center items so their center is on the same X coordinate as that of the first selected item

Vertically : center items so their center is on the same Y coordinate as that of the first selected item

Select All : selects all the window contents

Background : pops up a shade menu for setting the window background shade

Summary : creates a TEdit window listing a summary of the window contents. Only interesting properties are described, depending on the item type. Groups contents are indented hierarchically.

Import : allows items importation from a Free Menu. This function works but is currently bugged : importing items with a MENU property is not supported ; when importing groups only their contents are imported.

Compute : generates a description list of the items suitable for the FREEMENU function. The list is stored in the FMC-DESCRIPTION global variable. Opens a Free Menu built out from FMC.

Get : loads the contents of a FMC window, previously stored on disk by a Put operation. The loaded items (groups) are added to the current contents of the window.

Put : saves the contents of a FMC window on disk.

Fixed Menu : when the right menu is popped up by the right mouse button, attaches the menu to the main window. Once the menu is fixed, has no effect.

The Item Properties menu

APPLY : if the selection is unique sets the selected item properties to the properties described in the menu. If the selection is multiple, pops up a menu of properties and sets the selected property of all the selected items according to the menu.

SHOW : updates the menu according to the selected item, thus allowing editing its properties.

NEW : creates a new item which properties are described in the menu.

TYPE : lets the user specify the TYPE property from a pop-up menu.

LABEL : lets the user edit the LABEL property. If no label is edited the item will be displayed in FMC with the pseudo-label '*NOLABEL*'.
Right-buttoning in this field will start label edition, clearing the field first.

Middle-buttoning puts the cursor in the GETREGION state, and sets the label to the bitmap specified by the user.

Middle-buttoning puts the cursor in the GETREGION state, and sets the label to the bitmap specified by the user.

ID : lets the user edit the ID property. The edited string is always MKATOMed in the description list.

FONT : FAMILY, SIZE and FACE allow font descriptions from pop-up menus.

BOX : BOX=0 means no box.

BOXSHADE, BACKGROUND : pop up a shade menu, including an 'OTHER' option for shade editing.

MENU : opens a SEdit window where the user specifies the MENUITEMS, MENUFONT and MENUTITLE properties. The list must be of the form (MENUITEMS [MENUFONT] [MENUTITLE]).

INITSTATE : pops up a menu of possible INITSTATE values, depending on the item TYPE and possible MENUITEMS.

CHANGESTATE, SELECTEDFN, DOWNFN, HELDFN, MOVEDFN : open a SEdit window for the corresponding property. The edited list can be of the form (FUNCTION function-name) or a LAMBDA-expression.

LINKS : pops up a menu with 2 items : 'Add Link' and 'Remove Link'. 'Add Link' prompts the user to click on the item that is to get linked (this item must have an ID). 'Remove Link' removes the link.

INFINITEWIDTH : this toggle item is suitable for EDIT or NUMBER items only.

MESSAGE : starts editing the MESSAGE property (right buttoning clears the field first).

The Group Properties menu

APPLY, SHOW, ID, BOX, BOXSHADE, BACKGROUND behave in the same way as in the IP window.

COLLECTION : starts editing a COLLECTION name. Specifying a COLLECTION property is suitable only for groups which items are NWAY.

DESELECT : a toggle item whose value is relevant only for COLLECTIONS.

About item shaping

The effects of middle buttoning inside an item is different whether the item is boxed or not.

If the item is boxed, shaping will be constrained as described in the sample session, i.e. BOXSPACE must be the same horizontally and vertically.

If the item is not boxed, shaping is constrained so that only the item's width can be changed, in fact modifying the MAXWIDTH property.

Copy functions

The effects of pressing the COPY key and left buttoning when a FMC window has the TTY depend on what is to be copied :

- when clicking in a SKETCH window, the selected objects are made a graphic LABEL
- when clicking in a FMC window, the selected items are copied in the target window (the source and the target can be the same).